

A Prototype System for Transnational Information Sharing and Process Coordination: System Demo

S. Su, J. Fortes, T. R. Kasad, M. Patil, A. Matsunaga, and M. Tsugawa, University of Florida
V. Cavalli-Sforza, J. Carbonell, and P. Jansen, Carnegie Mellon University
W. Ward and R. Cole, University of Colorado
D. Towsley and W. Chen, University of Massachusetts
A. I. Antón and Q. He, North Carolina State University
C. McSweeney, University of Belize
L. de Brens, J. Ventura, and P. Taveras, Pontificia Universidad Católica Madre y Maestra
R. Connolly, C. Ortega, and B. Piñeres, Organization of American States
O. Brooks, National Drug Abuse Control Council, Belize
M. Herrera, National Drug Council, Dominican Republic

Demo Description

Global problems such as disease detection and control, terrorism, immigration and border control, illicit drug trafficking, etc. require information sharing, coordination and collaboration among government agencies within a country and across national boundaries. Under the support of a grant from the National Science Foundation of the United States, researchers at seven universities (Carnegie Mellon University, University of Belize, University of Colorado, University of Florida, North Carolina State University, University of Massachusetts and Pontificia Universidad Católica Madre y Maestra of the Dominican Republic) and experts from agencies in three countries (the Organization of American States (OAS) of the United States, the National Drug Abuse Control Council of Belize's Ministry of Health, and the National Drug Council of the Dominican Republic) are developing and integrating information technologies to enable resource sharing, coordination and collaboration among agencies of the collaborating countries. A prototype of a transnational information system has been implemented and demonstrated at the ministerial level in Belize in December 2003. It integrates a distributed query processing system, an event server, and an event-trigger-rule server developed at the University of Florida, a machine translation system developed by Carnegie Mellon University, a conversational interface developed at the University of Colorado, and a Web-services infrastructure jointly implemented by collaborating universities to achieve the interoperability of these component systems. The research group would like to demonstrate a refined version of the system at dg.o2004. The demonstration will accompany a research paper with the same title that has been submitted to the conference.

The architecture of the prototype system is shown in Figure 1 and is fully described in a companion paper. It consists of a host site and the sites of participating countries and their agencies. In the prototype implementation, we use two sites (one in Belize and the other in the Dominican Republic) to represent the countries' agencies. The data used to test and demonstrate the developed technologies are artificial data, generated based on the actual port-of-entry and exit forms used by these two countries. No real data is used for testing and demonstration purposes for privacy protection reasons.

Both countries have local databases that store immigration, border control and government process-related data. These databases are managed by their own local, heterogeneous Database Management Systems (DBMSs). The agents at ports-of-entry in each country use the local DBMS to enter, access and manipulate their data. Those data that a country is willing to share with the agencies of another country are specified in an export schema, and the integration of all the export schemas forms a global schema. The global schema is used to automatically generate query forms in different languages, through which authorized users in participating countries can query against the distributed databases stored in any of these countries. The users of this system are personnel at port-of-entry stations, government agencies and other authorized individuals.

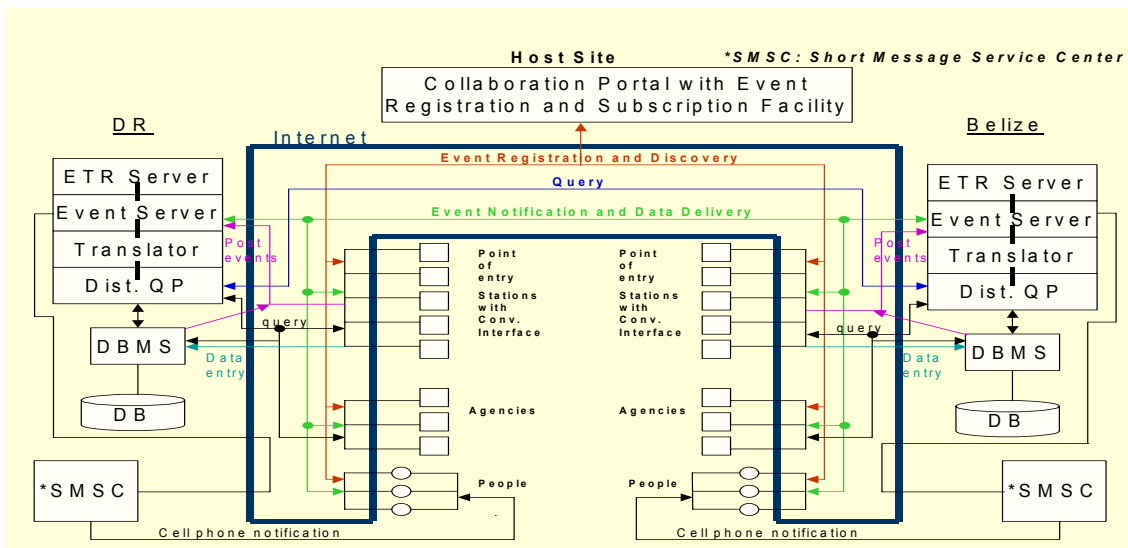

Figure 1. Architecture of the Prototype System

The replicas of software components installed at each of the participant countries' sites are briefly explained below. The **Distributed Query Processor (DQP)** provides a **form-based interface** as well as a **Conversation-based Interface** to allow users to query the distributed data. It uses a **Machine Translation System** to translate between English (used in Belize) and Spanish (used in the Dominican Republic) queries and data so that a user can issue a query in one language and receive the query results in the same language, regardless of the language of the data. The Distributed Query Processor with its interfaces and the Machine Translation System enable transnational information sharing. Another main function provided by the prototype system is event-trigger-rule processing. Authorized users in the participating countries can define and register events of common interest (e.g., a person wants to enter a country, or a person is on a watch list) at the Host site by using its **Event Registration and Subscription Facility**. Other users can browse and subscribe to these events and specify event filtering condition(s) for receiving event notifications (e.g., the person entering the country or the person on the watch list is from a certain country) when the subscribed events occur and the filtering conditions are satisfied. The subscribers also specify the desired means of notification (e.g., by emails, short messages to cell phones, and/or activation of application programs or processes defined as Web-services). The subscription and filtering information of an event is sent to the **Event Server** of participating sites where the event may occur. When an event occurs, the Event Server processes the registration and filtering information to decide which subscribers to notify. It will also notify the local **Event-Trigger-Rule (ETR) Server** to trigger rules associated with the event. Additionally, it will also notify the Event Servers of other collaborating countries, which in turn notify their ETR Servers to process the rules that are associated with the occurred event. Events are parameterized; the values of the parameters specify event-related information (i.e., the event data) specific to an occurrence of an event type. The event data can be passed to rules that examine the data conditions associated with the event. Distributed rules are used to specify different countries' policies, regulations, constraints and security and privacy rules and are enforced by replicas of the ETR Server. The Event Registration and Subscription Facility at the host site and the Event Server and the ETR Server at participants' sites together enable the close communication, coordination and collaboration of participating countries and their agencies.

In this demo a 3-laptop setup will be used to illustrate several usage scenarios for the prototype system. Each laptop emulates a country location's capabilities and requirements. Scenarios to be considered include the access of shareable information across borders, the transnational registration and notification of events, and the alerting of border crossings by dangerous individuals on a watch list.